

## CRYSTAL RECEIVERS FOR THE MW AM BAND

In this section we'll focus on simple crystal radios for the 540kHz to 1650kHz AM broadcasting band. We shall start with the very basic ones and then progress towards the amplified versions. The designs will make use of a coil wound on a cylindrical or rectangular ferrite bar, the type found in portable AM receivers. This coil receives the generic name of ferrite antenna. It has the effectiveness of an air-cored antenna coil coupled to an outside aerial of several meters long.

Our first schematic diagram (Fig.1) refers to a basic crystal set using a pair of 2000-ohms DC-resistance magnetic headphones, with a series connected parallel R-C network. This network reduces the loading imposed by the headphones on the tank circuit, increasing the selectivity of the receiver, or the ability to "separate" adjacent stations. This will be highly appreciated by an operator trying to tune-in a weak signal with a strong transmitter occupying an adjacent channel.

The variable capacitor we shall use is a salvaged 500pF unit, usually a nominal 475pF double-gang capacitor (only one gang will be required). The ferrite antenna consists of 50 close-wound turns of Litz wire of a gauge similar to that found in home portables (we can also use solid enamelled copper wire #26 or #28 AWG). Prior to winding the coil, it is advisable to wrap the ferrite bar with thin cardboard or two layers of paper, in order to protect the wire from damage due to friction with the bar. Turns may be held in place using wax or some kind of adhesive tape. Around 185uH of inductance will be needed for this coil to tune down to 540kHz with the said variable capacitor. We can trim the inductance sliding the cardboard or paper cylinder along the ferrite bar. The detector diode is a germanium device and types 1N34, 1N60, AA119, etc. may be used.

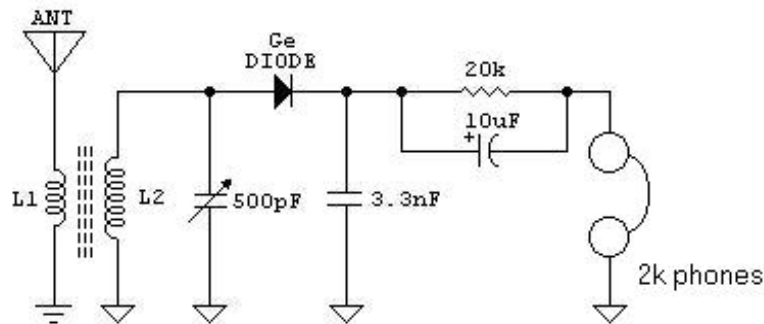

- L1: 4 turns of Litz wire (see text).
- L2: Main tuning coil - 50 turns of Litz wire (see text).
- ⌵: Circuit's common ground
- The diode detector is a germanium type.

Fig.1 Basic crystal receiver

Strong locals within 5km from our receiver's site should be heard through the headphones, especially if these are of a sensitive type. Medium strength locals require that our hearing room be a quiet place. Sometimes local weather will give us surprises. We may also find

that rotating horizontally the ferrite bar increases the volume of our signals or decreases them, due to the ferrite antenna's directivity. This may help reject interference from the strong ones when hearing a weak signal. If our site is at respectable distance from local transmitters (well, for our basic receiver that means more than 5km), an inverted-L outdoor antenna may be tried for improved reception. A horizontal span of at least 10 meters and a height of 5 meters minimum above obstructions will help. An additional coil will be needed for connection of the antenna. Four turns of Litz or solid enamelled copper wire, whatever has been used for the main tuning coil, will do. This winding should be separated 2.5cm (1") from the "cold" end of the main coil (the end connected to the circuit's common ground). One end of the small coil connects to the antenna; the other end should connect to a good ground system (connection to a cold-water pipe using a suitable clamp could be tried).

If a pair of 2000-ohms magnetic headphones is not available, a piezoelectric crystal or ceramic earphone paralleled by a 68k ohms resistor can be used instead. For this alternative, we discard the 3.3nF (0.0033uF) capacitor and the parallel 20k / 10uF network. Connections should be made as indicated by Fig.2 below. This earphone is a high-impedance type, very sensitive and should not be confused with the small low-impedance dynamic type commonly found in "walk-man" players.

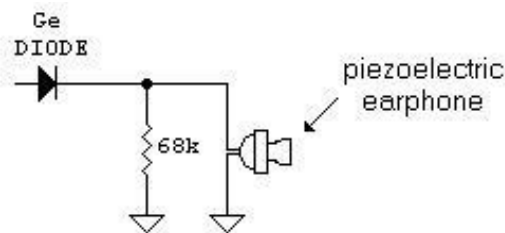

Fig.2 Connection of a piezoelectric crystal or ceramic earphone

Usually, loose-coupling an efficient antenna to the tuning tank renders a sensitive receiver having acceptable selectivity. The R-C network used in the basic crystal receiver discussed above also helps to improve selectivity. This idea has been in use for some years now and is a sample of what can be done at the headphones' end to enhance the ability of our radio to separate signals. In recent years, attention has also been given to the use of audio transformers in crystal sets to step-up the rather low headphone impedances to a larger value that will better match the audio source resistance, resulting in more volume from the headphones, while still maintaining a good selectivity. The audio source resistance is actually the diode's output audio resistance and is a result of the detection action taking place in the radio, whereupon radio frequency energy is converted into audio frequency signals.

Fig.3 shows a crystal receiver using an audio transformer to couple the headphones to the circuit. A transformer has two windings, the primary and the secondary. N is the turns-ratio, or ratio of the voltage impressed across the primary to the voltage obtained across the

secondary. Transformers also change impedance levels, so sometimes they are specified by their impedance transformation ratio or  $N^2:1$ .

The detector diode's small-signal output audio resistance ranges from around 40k ohms to about 150k ohms for available germanium diodes. Diodes having the higher resistances are preferred for maximum sensitivity and selectivity. This means that weaker signals will be detected and less loading will be imposed on the tuning tank. Accordingly, greater impedance transformation ratios will be required to match the headphone's impedance to the diode's.

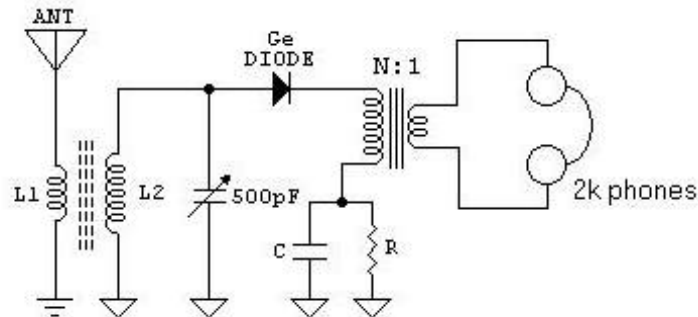

Fig.3 Crystal receiver using a coupling audio transformer

Magnetic headphones have a DC resistance of around 2k ohms and an average AC impedance that is around six times this value, or 12k ohms. Strictly speaking, AC impedance varies with frequency, so we refer to a measured average value over the 300Hz~3300Hz audio range. If our diode has, say, 60k ohms for its audio output resistance, then we will need a transformer having an impedance transformation ratio of 60k:12k, or 5:1. A word of caution here: the transformer should be a type that will work with the said impedance levels.

We have commented the usefulness of the R-C network when looking for selectivity improvements. The philosophy behind says that resistor R should be more or less equal to the headphones' average AC impedance, and capacitor C should be selected with a value that will by-pass audio signals. The capacitor's reactance at 300Hz should be no more than  $R/10$ . Values are not so critical.

When using an audio transformer for impedance matching (term meaning that we are trying to make the transformed load impedance equal the source resistance) an R-C network of the type described will be necessary. It should be connected as shown in Fig.3. Resistor R should be made equal to the transformed load impedance, as seen from the primary side of the transformer. With reference to the example above, R should be 60k ohms and an adequate value for C would be 0.1uF.

Before going into the group of circuits featuring post-detection audio frequency (AF) amplification, let's take a look to the configuration shown in Fig.4. The germanium diode paralleling the 2000-ohms headphones appears to be floating above ground. Apparently

there is something wrong with the schematic. However, if we realize that something must be coupling radio energy from the diode's cathode end to the circuit's common ground, permitting proper operation of the receiver, we will be on our way into solving the mystery.

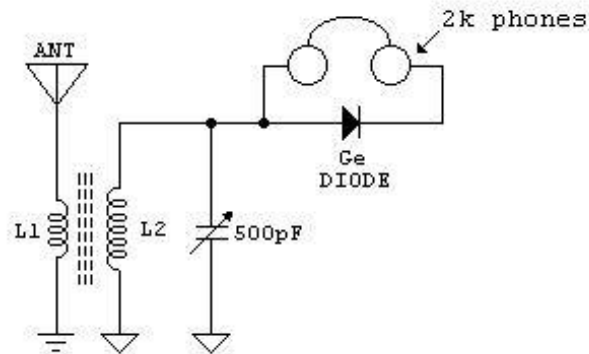

Fig.4 Floating-diode crystal receiver

And the answer is that.....naturally occurring stray capacitance from headphones and diode's cathode to common ground closes the circuit for radio frequency currents, permitting detection to take place in the usual way. So we happily get AF currents flowing through the headphones.

Now we will give a couple of examples of crystal sets featuring AF amplification. The first schematic (Fig.5) shows a receiver that uses a germanium AF transistor. Germanium amplifying devices exhibit at room temperature relatively large values of leakage collector current, or  $I_{ceo}$ . PNP transistors find this current just sufficient for their amplification factor  $\beta$ , or  $H_{FE}$ , to build up to a useful level. This is the case of European types AC125, AC126, AC188 and others. This is also certain for many US and Japanese types, such as 2N109, 2N188A, GA53677,....., 2SB22, 2SB370, 2SB496,..... The list is rather long. The good news is that we can dispense with the usual base bias resistive network, and still make a very simple amplifying stage. The addition of AF amplification will give our basic receiver extra volume. It should be noticed that there is no DC path between the diode and the transistor's base. The 100k ohms potentiometer is a volume control.

Our second amplified receiver (Fig.6) makes use of a 2N3904 silicon NPN transistor. We need external base bias for our amplifying device this time, as silicon transistors exhibit much less collector leakage currents. The 200k ohm resistor biases the transistor's base so collector to ground voltage is around 1 volt. We also need here to isolate the base from the potentiometer for DC currents. We use the 0.1uF capacitor for this purpose. We must invert the 1.5V battery's polarity for this circuit, as currents in NPN transistors flow in opposite direction to that of PNP devices.

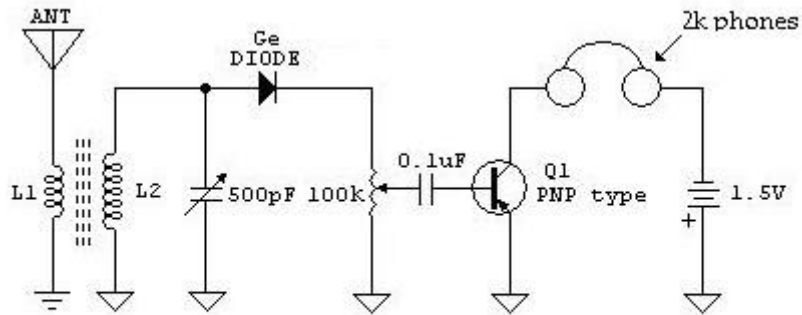

Fig.5 Crystal receiver with AF amplification using a germanium transistor

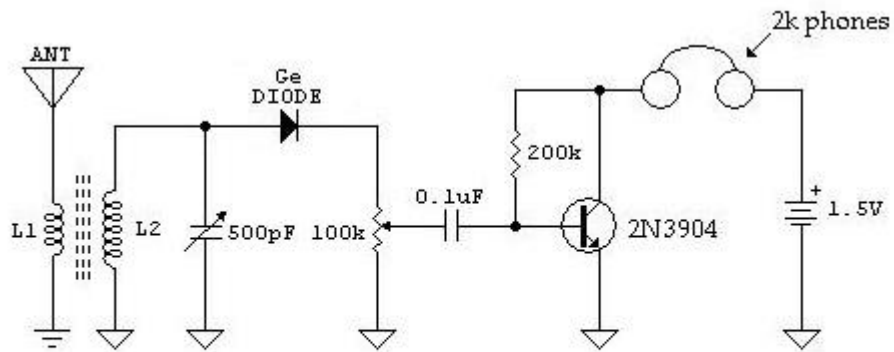

Fig.6 Crystal receiver with AF amplification using a silicon NPN transistor

Ramon Vargas Patron  
[rvargas@inictel.gob.pe](mailto:rvargas@inictel.gob.pe)  
 Lima-Peru, South America  
 May 16<sup>th</sup>, 2005